

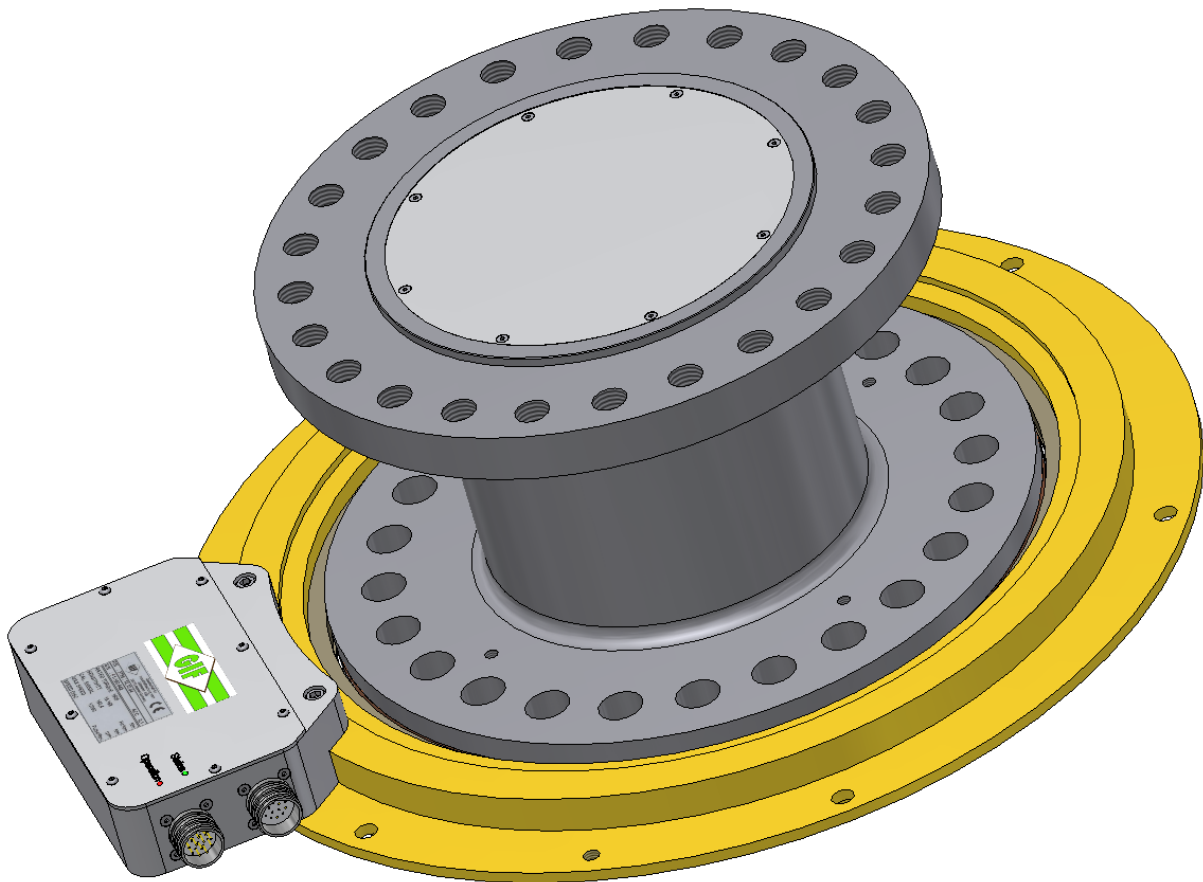

Supplement Manual

F3iS – flange

(56000Nm – without speed detection)





Mounting the stator

mount stator ring with 6 hexagon socket screws, DIN912, size M10

Recommended tightening torques for screws

Rated Torque Nm	PCD mm	Size	Quantity	Quality	Tightening Torque Nm
56000	290	M20	24	12.9	690

axial position: stator – rotor

optimum position

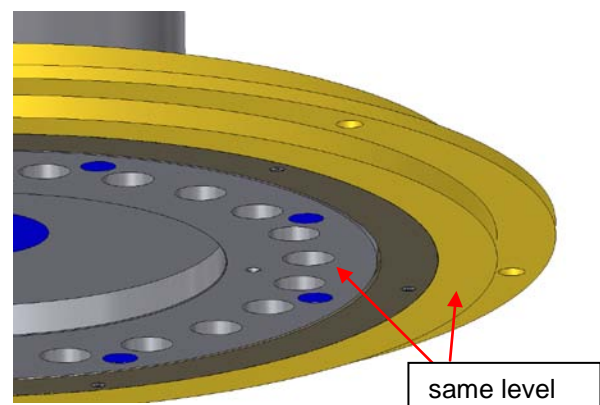
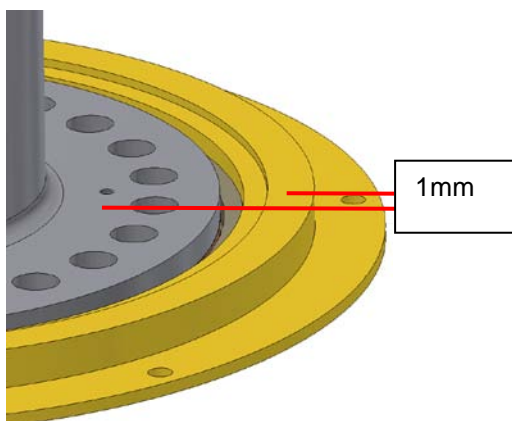
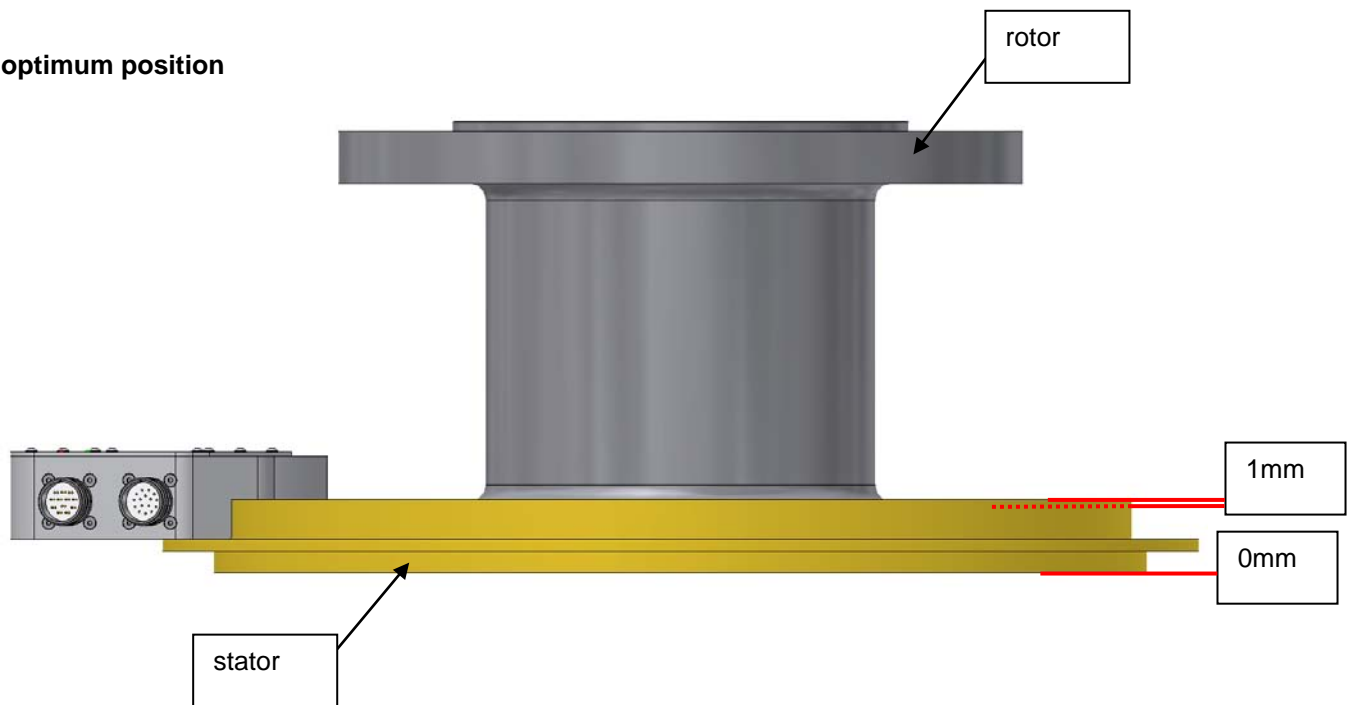



maximum position

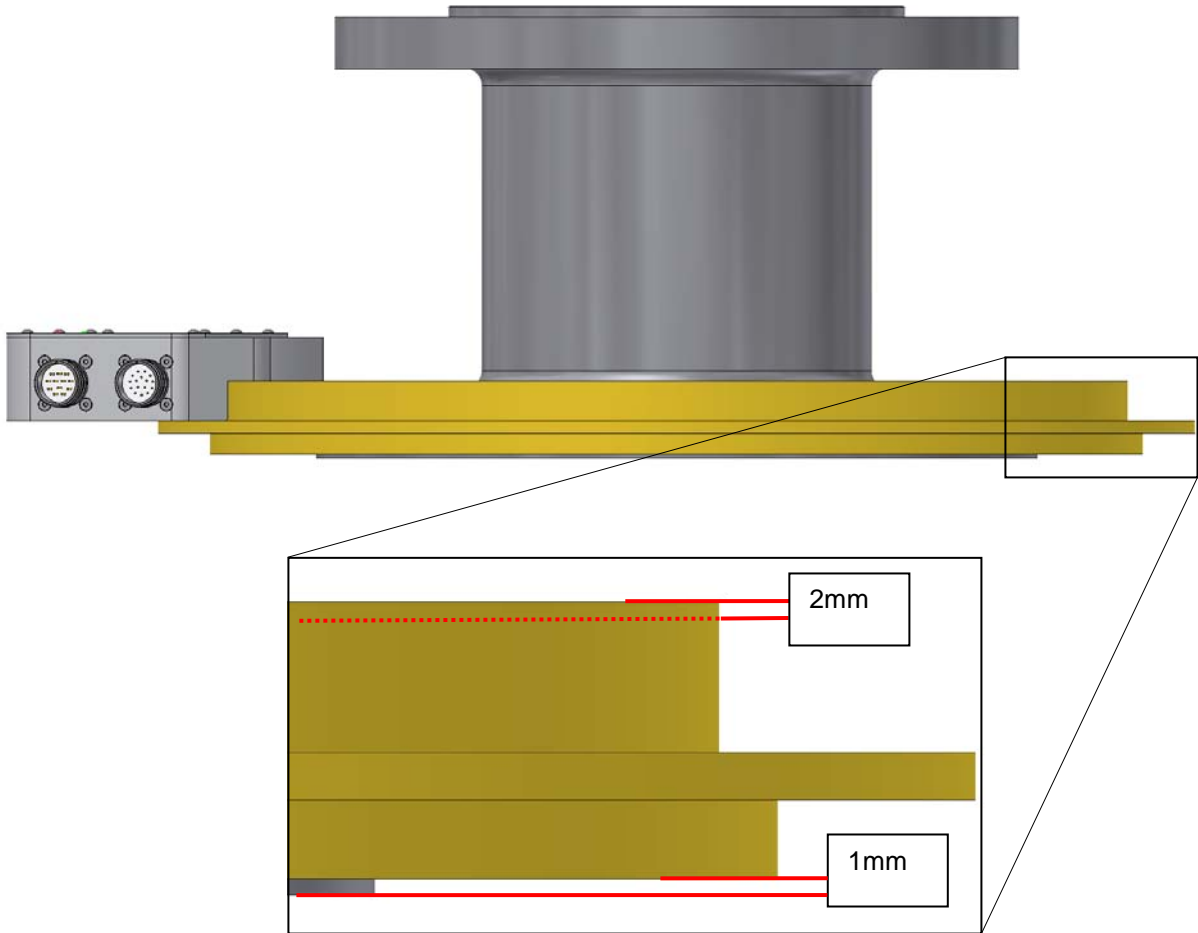



minimum position

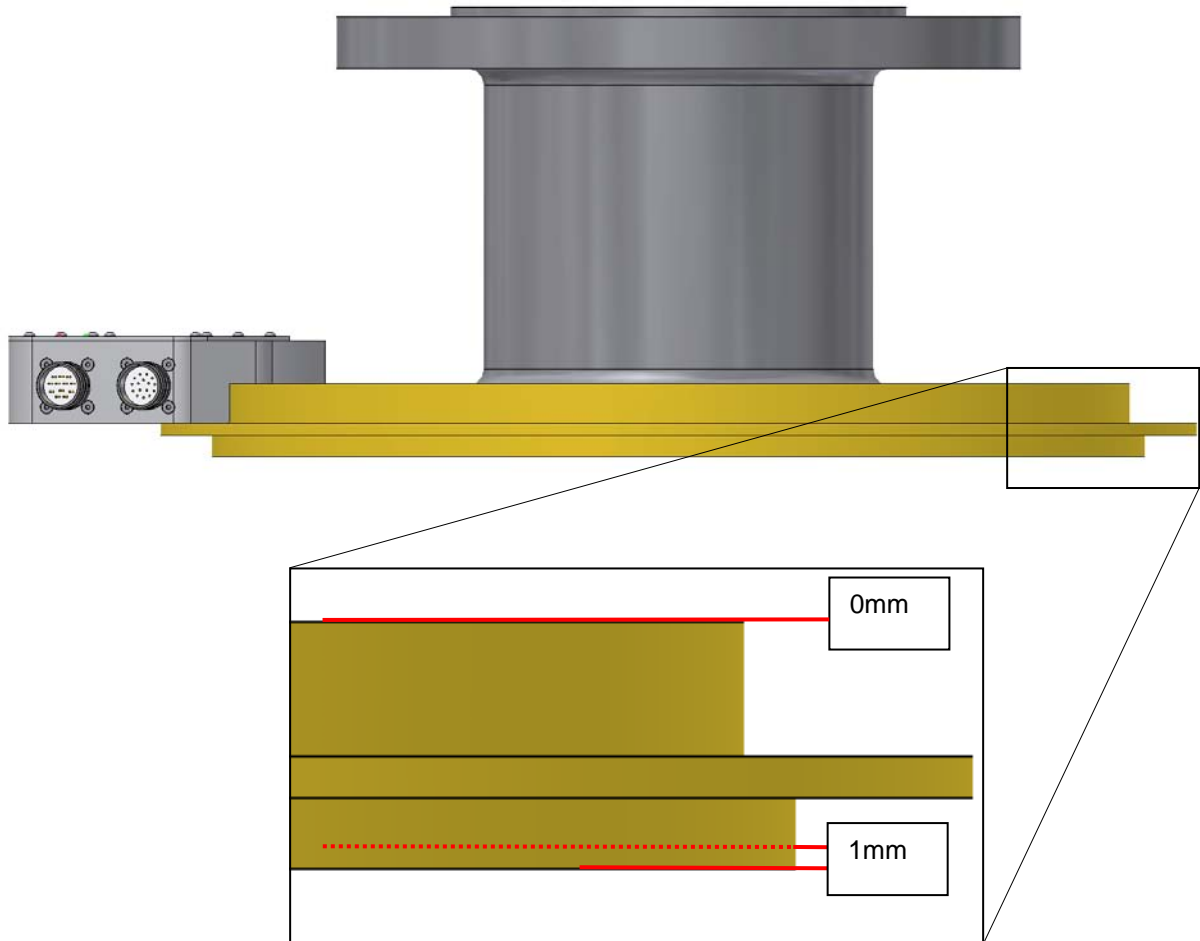



tolerance of the rotating axis (air gap: rotor – stator)

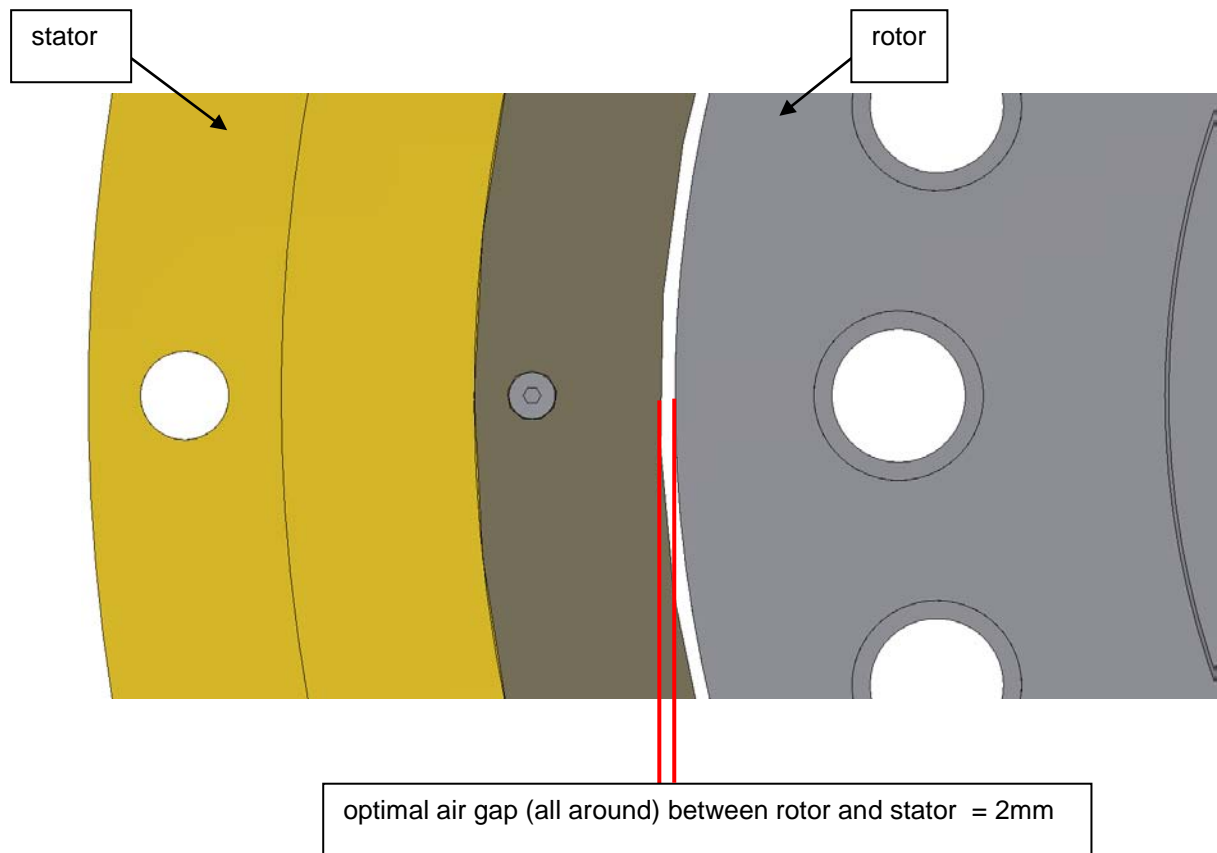

CAUTION! : The rotor may never touch the stator.



drawing of the measuring system

